

18V LXT® LITHIUM-ION BRUSHLESS CORDLESS COUPLE SHAFT POWER HEAD KIT WITH 13" STRING TRIMMER & 10" POLE SAW ATTACHMENTS (4.0AH)

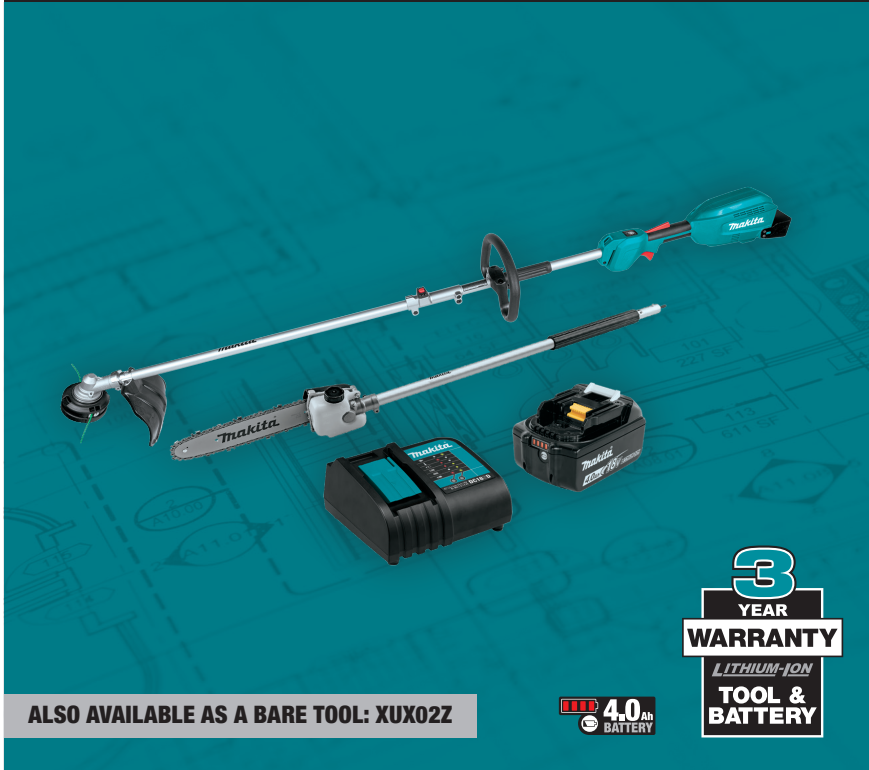

ALSO AVAILABLE AS A BARE TOOL: XUX02Z

4.0Ah BATTERY

3
YEAR
WARRANTY
LITHIUM-ION
TOOL & BATTERY

PRODUCT HIGHLIGHTS



DESIGN

Lever style lock system allows for quick tool-less installation and replacement of attachments



STRING TRIMMER

3 easy steps to load line into bump and feed trimmer head: align, feed and twist



CONTROL

High/Low speed button with variable speed trigger for power and run time management



POLE SAW

10" Pole Saw Attachment provides 7 foot fixed length for trimming hard to reach branches

RELATED PRODUCTS

1. Twisted Trimmer Line, 0.080", Green, 175', 1/2 lbs. (T-03866)
2. 10" Saw Chain, 3/8" LP, .050" (E-00212)
3. 42" Shaft Extension Couple Shaft Attachment (LE400MP)
4. 20" Articulating Hedge Trimmer Couple Shaft Attachment (EN401MP)
5. Edger Couple Shaft Attachment (EE400MP)



NEW TOOL OVERVIEW XUX02SM1X4

LXT BRUSHLESS

FEATURES

- No gas, emissions, oil mixing or pull starts
- BL™ Brushless Motor delivers up to 7,000 RPM with 13" String Trimmer Attachment and 3,940 FPM with 10" Pole Saw Attachment
- Lever style lock system allows for quick tool-less installation and replacement of attachments
- High/Low speed button for power and run time management
- Variable speed trigger for controlled cutting speed
- 13" String Trimmer Attachment includes rapid loading bump and feed trimmer head that loads line in seconds with 3 easy steps: align, feed and twist
- 10" Pole Saw Attachment provides 7 foot fixed length for trimming hard to reach branches
- Compatible with a variety of Makita couple shaft attachments (sold separately)
- Features Extreme Protection Technology (XPT™) which is engineered to provide increased dust and water resistance in harsh job site conditions

SPECIFICATIONS

Cutting Swath	13"
No Load Speed (var. 2 spd)	0 - 5,000 / 0 - 7,000 RPM
Arbor Shaft	M10 x 1.25 LH
Guide Bar Length	10"
Chain Speed	3,940 FPM
Net Weight (with battery)	9.2 lbs.
UPC Code (XUX02SM1X4)	088381-732147
UPC Code (XUX02Z)	088381-732062

STANDARD EQUIPMENT

XUX02SM1X4

- 18V LXT® Brushless Power Head (XUX02Z)
- 13" String Trimmer Couple Shaft Attachment (EM409MP)
- 10" Pole Saw Couple Shaft Attachment (EY401MP)
- 18V LXT® Lithium-Ion 4.0Ah Battery (BL1840B)
- 18V LXT® Lithium-Ion Charger (DC18SD)

XUX02Z

- 18V LXT® Brushless Power Head (XUX02Z)